

GRUNDFOS DATA SHEET

VFS 20-400

Vortex Flowsensor Standard, 20-400 l/min



TM03 8209 0807

Fig. 1 VFS 20-400 sensor

Technical overview

Grundfos Direct Sensors™, type VFS, is a series of combined flow- and temperature sensors (two-in-one) based on the principle of vortex shedding behind a bluff body. The VFS sensors are designed for high-volume production and are fully compatible with wet, aggressive media. The VFS sensor utilises MEMS sensing technology in combination with a novel packaging concept using corrosion-resistant coating on the MEMS sensor element. This makes the VFS sensor very robust and ideal for high-volume OEM applications. VFS sensors are available for flow ranges of 1-12, 1-20, 2-40, 5-100, 10-200 and 20-400 l/min.

The trademark Grundfos Direct Sensors™ is owned and controlled by the Grundfos group.

Applications

- thermal management in solar heating systems
- industrial process flow control
- flow rate detection for pump controls
- monitoring of pumps, valves and filters
- cooling and temperature control
- domestic hot-water systems
- heat metering (solar - heat pumps).

Features

- flow ranges: 1-12, 1-20, 2-40, 5-100, 10-200 and 20-400 l/min.
- based on vortex shedding
- voltage output (ratiometric, ideal for use with a microprocessor and PLC)
- compact and robust design
- approved for potable water: WRAS, KTW, W270, ACS.

Benefits

- no moving parts
- flow and temperature sensor in one package (two-in-one sensor)
- fast temperature response (direct media contact)
- compatible with wet, aggressive media
- cost-effective and robust construction.

Specifications

Flow	
Measuring range	20 to 400 l/min
Accuracy ($\pm 1\sigma$), 0 to 100 °C	$\pm 1.5\%$ FS
Response time Start up flow / no flow (90 %)	< 1.0 s
Resolution	2.0 l/min
Temperature	
Measuring range	0 to 100 °C
Accuracy ($\pm 1\sigma$), 25 to 80 °C	± 1 °C
Accuracy ($\pm 1\sigma$), 0 to 100 °C	± 2 °C
Response time (63.2 % at 50 % FS flow)	< 1.0 s
Resolution	0.5 °C
Media and environment	
Media types	The sensor is compatible with liquids (kinematic viscosity ≤ 2 mm ² /s)
Media temperature (operation)	0 to 100 °C
Media temperature (peak)	-25 to 120 °C, non-freezing
Ambient air temp. (operation)	-25 to 60 °C
Ambient air temp. (peak)	-55 to 90 °C
Humidity	0 - 95 % RH, non-condensing
System burst pressure	> 16 bar
Electrical data	
Power supply	5 VDC ($\pm 5\%$). Grounding of the sensor supply is required (PELV)
Output signals	Ratiometric
Flow signal	0.5 - 3.5 V (Zero at 0.35 V)
Temperature signal	0.5 - 3.5 V
Power consumption	< 50 mW
Load impedance	> 10 k Ω
Sensor materials	
Sensing element	Silicon-based MEMS sensor
Seal (sensor to housing)	EPDM rubber
Housing	Composites (PPS, PA66)
Flow pipe	PPA 40-GF
Wetted materials	Corrosion-resistant coating EPDM, PPS, PPA 40-GF
Environmental standards	
Enclosure class	IP44 (Non overmolded IP20)
Temperature cycling	IEC 68-2-14
Vibration (non-destructive)	20 - 2000 Hz, 10G, 4h
Electromagnetic compatibility	EN 61326-1
Dimensions	
Sensing element	47 x 40 x 20 mm, see drawings
Flow pipe	180 x 54 x 48 mm

If the equipment is used in a manner not specified by the manufacturer, the protection provided by the equipment may be impaired.

BE > THINK > INNOVATE >

Being responsible is our foundation
Thinking ahead makes it possible
Innovation is the essence

Dimensions (mm)

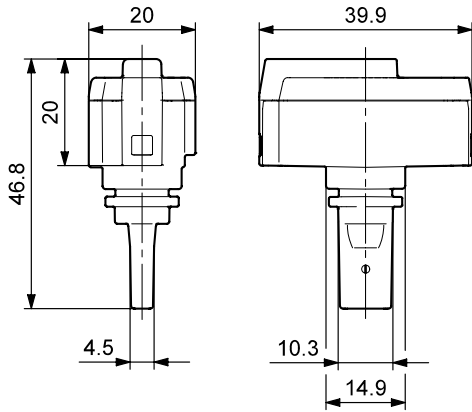

Fig. 2 Dimensional sketches of sensing element

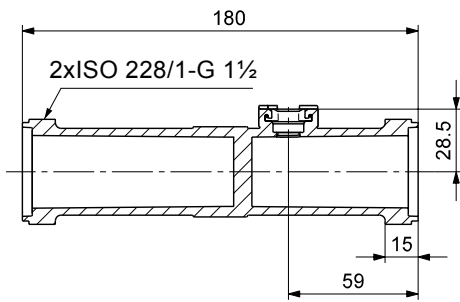

Fig. 3 Dimensional sketch of flow pipe

Type key

The sensor is labelled with a type designation.

	96	- XX	- XXX	XXXXX
Product number				
Revision				
Production year and week				
Consecutive number				

For more information, see
<http://www.grundfos.com/directsensors>.

96883469 1008	GB
---------------	----

Electrical connections

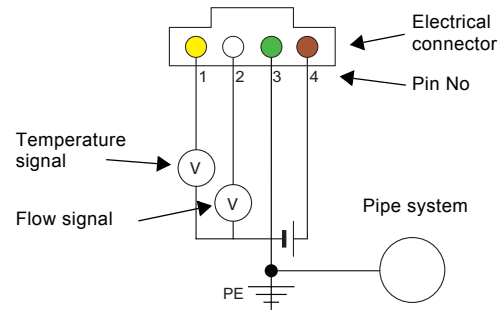

Fig. 4 Electrical connections

Pin configuration	Colour
1 Temperature signal (0.5 to 3.5 V relative to pin 3)	Yellow
2 Flow signal (0.5 to 3.5 V relative to pin 3)	White
3 GND (0 V)	Green
4 Power supply (+5 VDC), PELV	Brown

Power supply requirements

- 5 VDC
- separated from hazardous live circuitry by double or reinforced insulation
- power limitation: 150 VA; current limitation: 8 A.

Sensor output signals

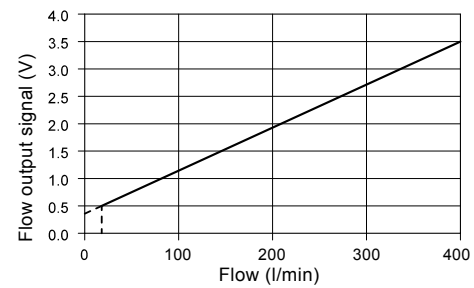

Fig. 5 Flow response

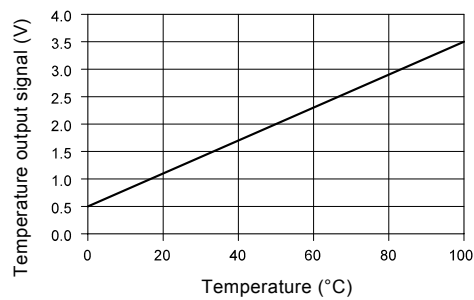

Fig. 6 Temperature response

Subject to alterations.

Grundfos Sensor A/S
Poul Due Jensens Vej 7. DK-8850 Bjerringbro. Denmark
Telephone: +45 87 50 14 00

GRUNDFOS 
www.grundfos.com