

SOLARHOT™

Glycol Solar Thermal System

Installation/ Owner's Manual



Description / Applications ***System Overview***

The SOLARHOT™ solar thermal glycol system can provide 70-90% of your domestic hot water needs annually. A water/glycol mixture running through a solar collector is heated by the sun. The heat is then transferred to the potable water in your hot water tank. Water is circulated through each “loop” by a high efficiency circulation pump through a brazed-plate heat exchanger. The heat transfer fluid has a very low freezing point which keeps your collectors safe from freeze damage.

The pumps are controlled by a differential control which reads the temperatures at the collector and in the tank. It provides power to the pumps when the temperature in the collectors is 16° higher than the tank water temperature. The control includes a digital display with a touch pad to easily program temperature limits, differentials, vacation modes, and other advanced options.

OG-300 Systems: S-SV-G100, S-SV-GC100P64, S-SV-GC100P52, S-SV-GP64-120, S-SV-GP80-120, S-SV-GS40, S-SV-GS64, S-SV-G100ET, S-SV-GET30, S-SV-GET60-120, S-SV-GET30-120, S-SV-GASWS58A, S-SV-GASWS58A-25, S-SV-GGASWS58A-30, S-SV-GP80G, S-SV-GP64G, S-SV-G52G, S-SV-GE32, S-SV-GE40, S-SV-GS32, S-SV-GS40, S-SV-GE52, S-SV-GE64, S-SV-GS64, S-SV-GE64-120, S-SV-GE80-120, S-SV-GS80-120, S-SV-GE52G, S-SV-GE64G, S-SV-GE80G, S-SV-GS64G, S-SV-GE78-120, S-SV-GE96-120, S-SV-GS96-120, S-SV-GE96G-120, ZASP-2FP, ZASP-3FP, ZASP-4FP, S-SV-GEHC58, S-SV-GEHC87, S-SV-GUMA64, S-SV-GUMA64-120, S-SV-GUM40, S-SV-GUMA40-120



Contents

Features.....	2
SolarHot Glycol Advantage	2
Safety	2
Certification	2
Materials List	3
GS_P Glycol System.....	3
GS_P_RM Glycol System with Adjustable Mount Hardware	3
Additional Materials Required	4
Glycol System Specifications	4
Installation	5
Collector Orientation	6
Installing the Collectors	7
Installing the Mounting Brackets	7
Preparing the Collectors.....	8
Mounting the Collectors	9
Connect to Pipes.....	11
Installing the Temperature Sensor	12
Pipe Runs.....	13
Installing the Tempering Valve.....	13
Mounting the SolVelox on the Storage Tank	14
Installing the Differential Control	14
Check Collector Loop for Leaks	17
Charging the System.....	17
Starting the System.....	18
Check System Operation	18
Operation	18
Vacation Settings	18
Emergency Shut Off.....	19
Maintenance.....	19
Freeze Protection.....	19
Clear Sediment from Strainer.....	19
Descaling the Heat Exchanger	19
Change Heat Transfer Fluid	20
Pumps	20
Service	20
Warranty Information	21

**WARNING**

Electrical Shock, Fire, Explosion and Burn Hazards

This system must be installed, adjusted, and put into operation only by a trained, qualified professional or service agency in accordance with the National Electric Code ANSI/NFPA 70 (Canada CSA C22.1), state and local codes, and authorities having jurisdiction.

The installer must carefully read and follow the installation and service instructions contained in this manual. Also make these instructions available to the equipment owner, so they can be kept for future reference.

Features

SOLARHOT Glycol Advantage

SOLARHOT has uniquely created the SolVelox package, which pre-assembles and integrates an oversized stainless steel heat exchanger along with the pumps and valves necessary to drive a two-loop solar system. The heat exchanger and pumps are sized to meet the heat output of up to six solar collectors, so one SolVelox appliance provides an economical solution as you scale the system to meet your particular needs. Also, the SolVelox is externally mounted in order to reduce maintenance issues.

Safety

The best performance will come from a solar collector with aluminum sides and low iron solar glass well-sealed to hold the heat. These materials weigh 80-150 lbs., depending on the size of the collector.

**WARNING**

Electrical Shock and Fall Injury Hazard.

Use extreme caution when mounting collectors on a roof or when connecting any wiring or electrical hookups.

- ALWAYS use fall protection
- Secure all ladders on level ground
- Locate all possible hazards, overhead wires, loose shingles, etc.
- Make sure power is turned off before adding water to the system
- NEVER connect power to the water heater or storage tank until it has been filled.
- Use a tempering valve or mixing valve to prevent scalding
- Consult proper authorities and check with your local building inspector for permit requirements and local building codes before project commencement. The system must meet local code requirements for penetrating structural members and fire-rate assemblies.

Certification

The solar energy system described by this manual, when properly installed and maintained, meets standards established by the SRCC. This certification does not imply endorsement or warranty of this product by the SRCC.

Materials List

GS_P or GS_S Glycol System

System requirements:

- One to six (1-6) SOLARHOT Platinum or Silver solar collectors (Platinum include 1" gasketed unions)
- One (1) SOLARHOT SolVelox glycol pump package (pumps, heat exchanger with Elastomeric insulation, Steca differential control), including mounting bracket, six (6) screws, two (2) sensors (third sensor optional), strain reliefs for sensors, and 50 ft. sensor wire
- One (1) minimum 2 gal. expansion tank, (flex line and mounting bracket optional)
- One (1) flush mount hardware kit per collector
- One (1) solar dip tube
- One (1) ASSE 1017 certified mixing / anti-scald valve
- One (1) roof kit per collector array (flashing, caps, plug, reducing elbows), including...
 - One (1) 1/2" copper roof flashing with special adapter cap
 - One (1) 1/2" copper roof flashing with gooseneck
 - One (1) row kit (for Platinum collectors, Silver collectors add two (2) gasketed unions per collector or copper couplings and caps)
 - Two (2) 1"x1/2" elbows

GS_P_RM or GS_S_RM Glycol System with Adjustable Mount Hardware

System requirements:

- One to six (1-6) SOLARHOT Platinum or Silver solar collectors (Platinum include 1" gasketed unions)
- One (1) SOLARHOT SolVelox glycol pump package (pumps, heat exchanger with Elastomeric insulation, Steca differential control), including mounting bracket, six (6) screws, two (2) sensors (third sensor optional), strain reliefs for sensors, and 50 ft. sensor wire
- One (1) minimum 2 gal. expansion tank, (flexible line and mounting bracket optional)
- One (1) adjustable mount hardware kit per collector (telescoping legs to vary mounting angle)
- One (1) adjustable mount hardware kit per array
- One (1) solar Dip tube
- One (1) ASSE 1017 certified mixing/ anti-scald valve
- One (1) roof kit per collector array (flashing, caps, plug, reducing elbows)
 - One (1) 1/2" copper roof flashing with special adapter cap
 - One (1) 1/2" copper roof flashing with gooseneck
 - One (1) row kit (for Platinum collectors, Silver collectors add two (2) gasketed unions per collector or copper couplings and caps)
 - Two (2) 1"x1/2" elbows

Additional Materials Required

- Electric water heater to use for solar storage tank, 80 gal. minimum
- 1/2" copper or stainless steel tubing and standard fittings
*****Do **NOT** use PEX, PVC or other plastic piping *****
- Mounting hardware
- 1" elastomeric insulation (e.g. Nomaco K-Flex LS)
- PVC insulation jacketing (e.g. Speedline Smoke-Free PVC)
- Vinyl tape
- 40% GRAS propylene glycol heat transfer solution
- Drip pan (optional, see Installation Diagram)

Glycol System Specifications

GS_P and GS_P_RM

Congratulations on the installation of your SOLARHOT System! Correctly installed and maintained, your system should provide you with many years of uninterrupted solar hot water. The solar collectors are designed to last 25-35 years, electric water heaters 10-20 years, and pumps, controls, and valves 5-10 years. Local water quality and usage will greatly affect life expectancies.

Solar Collector: (Recommended)

SOLARHOT Platinum or Silver flatplate collectors

Solar Storage Tank (80 gal. minimum), not included:

Whirlpool EE3Z80HD055V

American Premier E62-80H-045DV

Rheem 81VR80TC-1

Lochinvar FTA082K

Pumps:

Collector Loop Glycol: Wilo Star 16 Tank Loop: Wilo Star 8B

Controller:

Differential Control TR 0301U, includes two (2) (third sensor optional) PT1000 sensors, one is prewired

Heat Exchanger:

SolarHot P-HX-210512

System Operating Parameters:

Pressure on a glycol system should be 25-30 psi

Flow meter should read about 5 gpm on the collector loop and 3.5 gpm on the tank loop

Installation

Refer to **Figure 1** for the relative location of the pipes, collectors, and SolVeloX pump package. The cold water supply line to the solar storage tank must be covered with a minimum of 7/8" x 1/2" insulation for 5 feet from the water heater. Please note that if the water storage tanks are located in or above living spaces, a drip pan with a drain line to the outside of the building is required.

Figure 1 - Installation Diagram

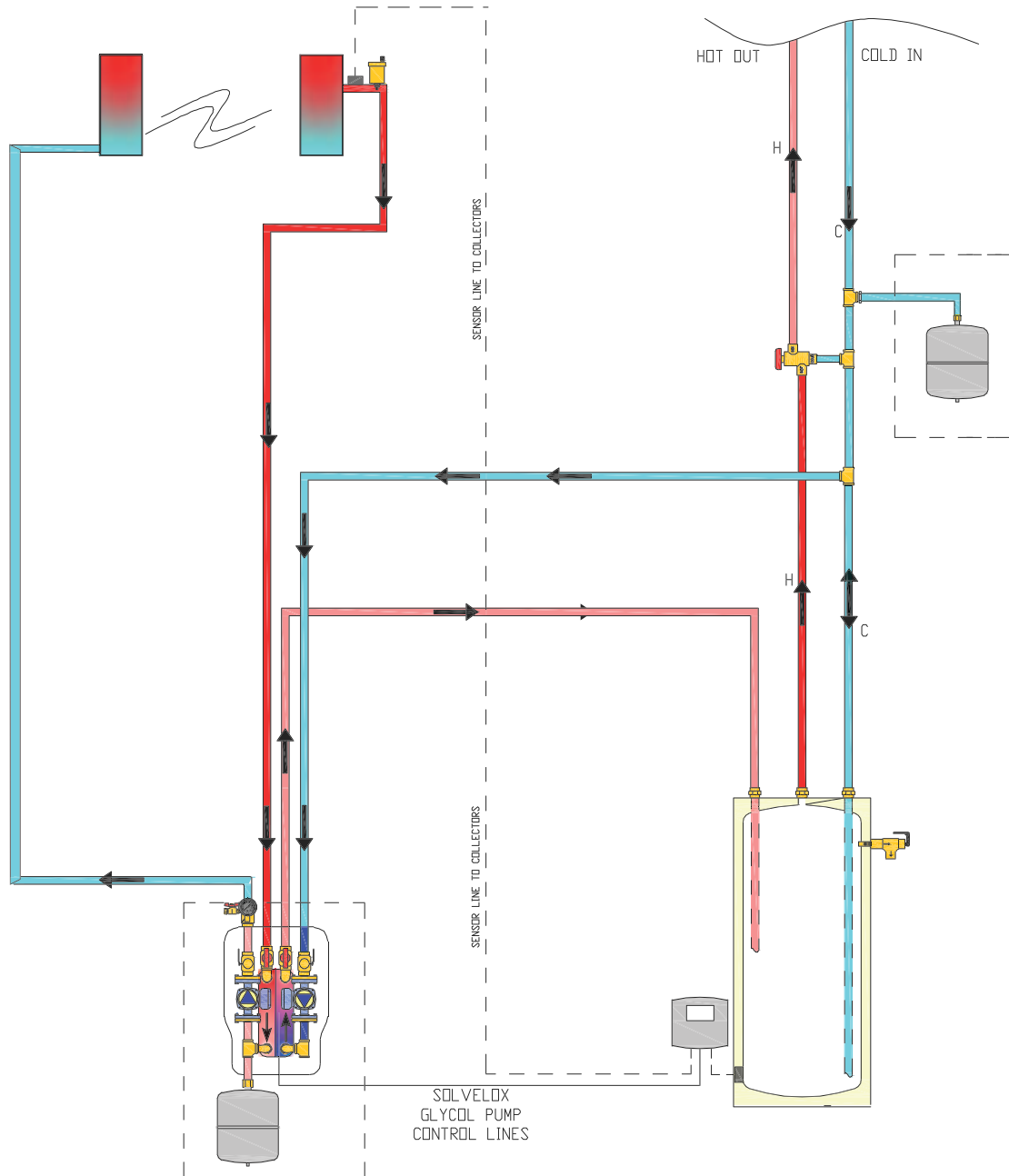

Notes:

- The pipe, heat exchanger, expansion tank, and pump size will be determined by the size of the collector array.
- All pipes 1/2" diameter minimum. **DO NOT USE PLASTIC PIPES!**
- An expansion tank should be installed on the potable water side for systems that do not allow backflow.
- Refer to manufacturer's instructions regarding installation of the tempering valve.

There are two basic methods for mounting collectors on the roof or ground, as outlined in **Figure 2**.

1. Flush Mount— This is the most common method. If the existing roof line is not suitable for any reason, the adjustable mount may be employed.
2. Adjustable Mount— This is sometimes required on a flat roof or in the case of a ground mount to optimize available solar energy.

Figure 2 - Mounting Options

Flush Mount:



Adjustable Mount:



Collector Orientation

The collectors should be mounted as close to due south as is reasonable, considering the roof line. However, if the collector is mounted within 45 degrees of south, any performance drop is insignificant. The aesthetics of flush mounting a collector on the roof will generally outweigh performance improvements less than 5%.

The collectors should ideally be inclined at the same angle as the location's latitude, i.e. if you are located in Raleigh, NC (latitude 38 degrees) you would ideally have the collectors inclined 38° from horizontal. Testing has shown that mounting a collector within $\pm 15^\circ$ of the site's latitude will not significantly degrade the collector's annual performance.

Pay close attention to the angle and direction of the roof line. If the roof line doesn't match the ideal criteria listed above, we recommend adding collector area as opposed to mounting the collector at a tilt. For example: If your roof faces the southeast, you may use three collectors instead of the two collectors which would be typical for a family of four.

Further, minimize the shade over the collectors. Collectors should receive 6-8 hours of direct sunlight each day for optimal performance.

WARNING Do not use plastic piping

PEX, PVC and other forms of non-metal pipes will burst at solar temperatures. Only use correctly sized copper or stainless steel pipes in solar heating system on both the solar and potable water loops. All connections to and from the SolVelox must be copper or stainless steel.

WARNING Fall Injury Hazard.

Prepare the roof to work safely, employing roof scaffolding methods approved by OSHA.

Installing the Collectors

Unfortunately stud finders for rooftops can be hard to come by, but it is still important to mount the collectors into the rafters. Here are some ways to locate a rafter:

- From inside the attic, drill an angled hole, about 45 degrees, at the intersection of the roof deck and the rafters of choice. Each spot where the drill penetrates the exterior of the roof should be near the center of its respective rafter.
- 2. Inside the attic, measure the distance from an existing roof protrusion to the nearest rafter. Use that same measurement on the outside of the roof to drill into the chosen rafter.
- 3. Drill into the roof from the outside. Then, inside the attic, measure from that drilled hole to the nearest rafter. Use the same measurement on top of the roof.
- 4. Using a 3/16" x 12" long drill bit, drill from the inside of the attic through the rafter to the outside.

Installing the Mounting Brackets

1. Draw a 10-foot long horizontal line at least 18" below the peak of the roof.

Figure 3 - Spacing



2. 97½" below the first horizontal line draw another 10-foot line as shown in **Figure 3**.
3. Locate the center of a rafter and mark vertically along the rafter with a chalk line between the two horizontal lines.
4. Using the rafter spacing, make vertical marks over the center of the rafters, marking all the rafters that the collectors will span.
5. Using the mounting foot as a template, hold the mounting foot at the center of each intersection. Holding the mounting foot at the intersection of the chalk lines, mark the holes with a marker. Repeat this procedure until each of the mounting foot locations have been marked (four mounting feet for each collector).
6. With a 3/16" drill bit, drill a pilot hole at each of the marks you just made.
7. Place the mounting feet over the pilot holes and, using 3/8" X 2 1/2" stainless steel lag screws, flat washers, and lock washers, screw them into the rafters as seen in **Figure 4a or 4b**.

Figure 4a - Flat Mount Shown**Figure 4b - Adjustable Mount Shown**

Preparing the Collectors

⚠ WARNING Burn hazard

When working with the solar collectors, cover the panels until installation is complete. Both the panels and unions quickly begin to collect heat and pose a burn hazard.

The end of the collectors with the SOLARHOT name plate should be installed closest to the ridge of the roof, as there are weep holes to release condensation on the other end. The corners of the collectors will have 1" unions preinstalled. These will be mounted with elbows as seen in **Figure 5a**. Depending on system flow configuration, the two ends not in use will have end caps as in **Figure 5b**.

Figure 5a - Collector Configuration**Figure 5b - Collector Configuration**

Mounting the Collectors

Refer to **Figure 7** for proper installation.

Figure 7a: Flush Mount

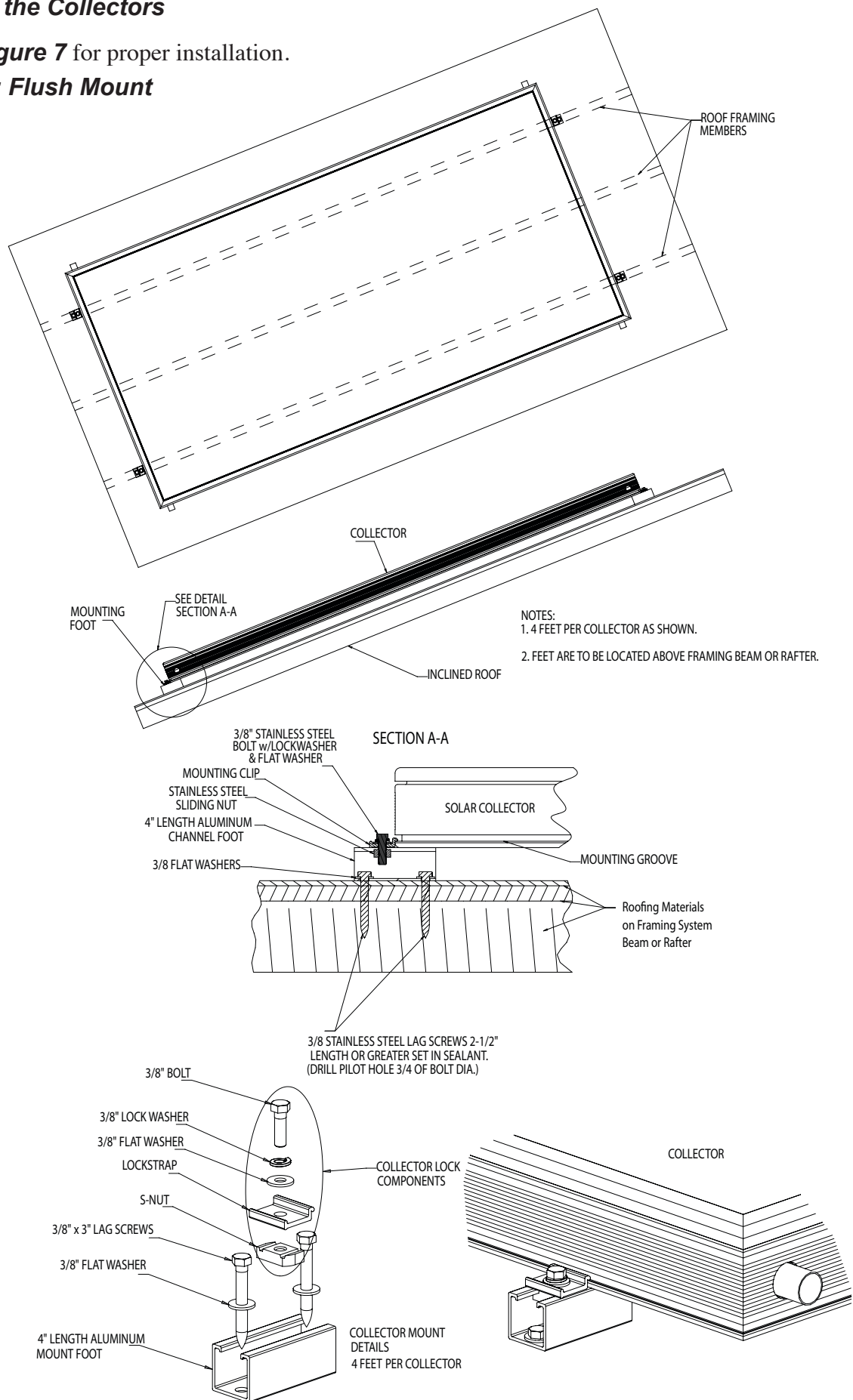

Figure 7b: Adjustable Mount

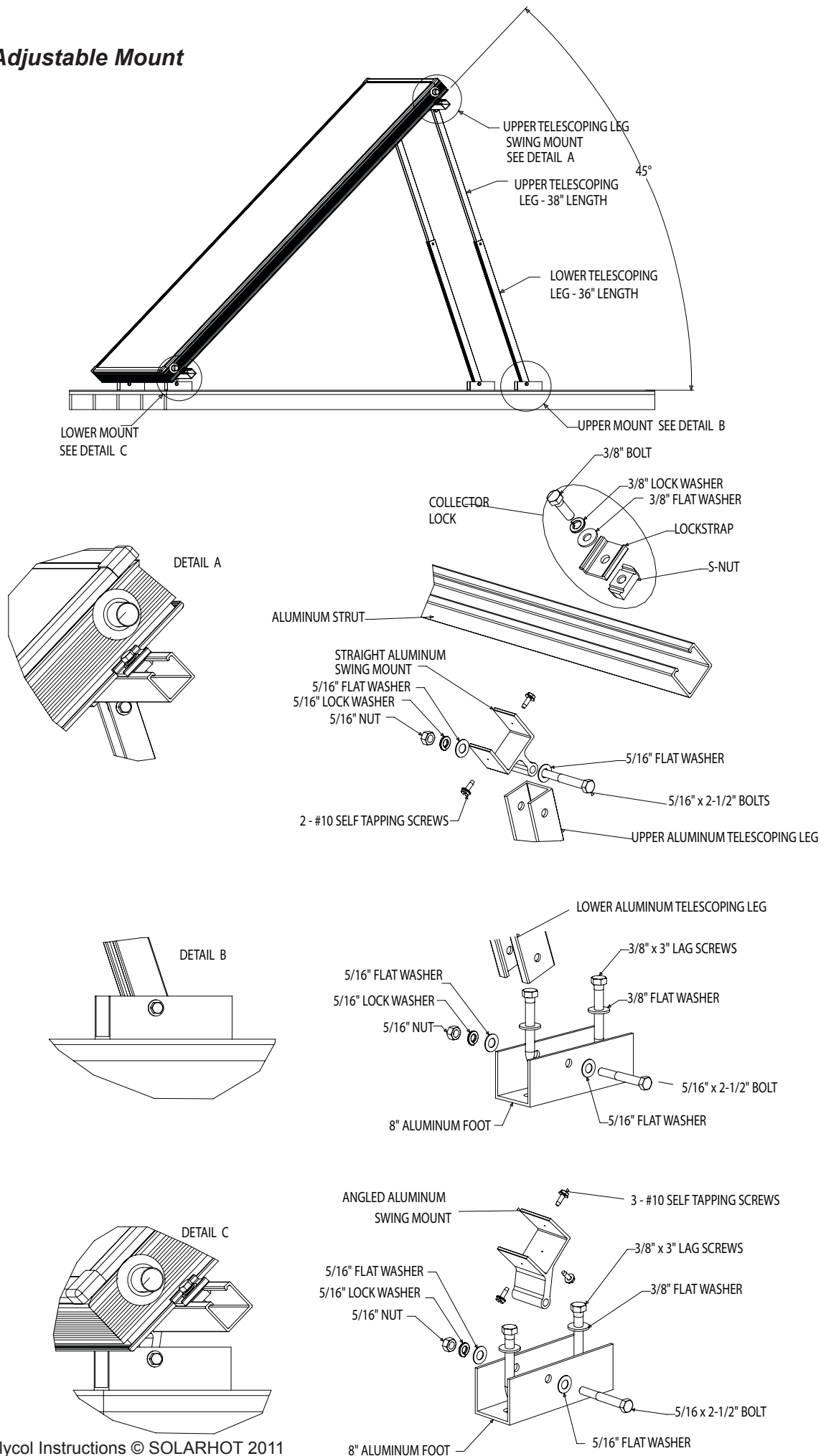
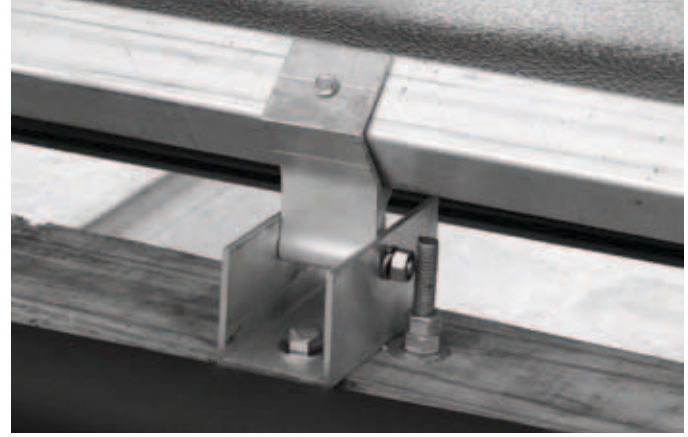

Figure 8a: Mounting Clips for Flush Mount



Figure 8b: Mounting Clips for Adjustable Mount



Mounting the Collectors

Mount the collectors so that there is a 1/4" drop per foot toward the inlet as in **Figure 6**. This facilitates proper system flow and drainage.

Refer to Figure 7 for proper installation.

1. The mounting clip is made up of two parts joined by a stainless steel bolt with a lock washer as in **Figure 8a and 8b**.

Figure 9: Joining Collectors



Before taking the collectors up to the roof, slide the stainless steel sliding nut into the anodized aluminum channel foot. Now carefully place the first collector so that the mounting clip fits in the mounting groove that runs around the bottom edge of the collector and tighten the bolt. Ensure that the clips are installed securely.

2. Mount the next collector so that the unions join to the first collector and secure the mounting clips as in **Figure 9**.

Connect to Pipes

1. Using a wood bit the same size as your pipes, drill a hole in the center of a shingle below where the bottom corner of the collector inlet will be and in the opposite corner, where the collector outlet will be.
2. Apply sealant to the underside of the copper flashing. Carefully raise the drilled shingle,

Figure 10 - Copper Flashing

place flashing underneath and insert collar through the hole as shown in **Figure 10**.

3. Run pipes from attic through the copper flashing and sweat connect them to the street elbows. **See “Pipe Runs” section for specific instructions.**

Installing the Temperature Sensor

1. Strap the PT1000 probe sensor to the copper pipe at the collector outlet using a stainless steel screw clamp as shown in **Figure 11a**.
2. Feed the sensor wire through the gooseneck of the copper flashing as in **Figure 11b**. The flashing can then be soldered to seal it from leaks.

NOTICE

If the water storage tanks are located in or above living spaces, a drip pan with a drain line to the outside of the building is required.

3. For sensor to operate correctly it must be isolated from exterior conditions. All of the exposed copper, as well as the sensor itself, needs to be completely covered with insulation and UV jacketing.

Pipe Runs

Use 1/2” copper tubing or larger. All pipes should be wrapped with at least 3/4” thick insulation. We

Figure 11a - Sensor Installation**Figure 11b - Sensor Installation**

recommend 1” Elastomeric insulation. Outdoor pipes should also be jacketed with UV protection material or some other means to protect it from moisture and ultraviolet deterioration. We recommend Nomaco K-Flex LS with Speedline Smoke Safe PVC Fitting Covers and vinyl tape. All pipes must be well supported or they will sag. Sagging pipes may trap water. The hanger should spread the load so that the insulation is not compressed. Place supports every 4.7 feet.

⚠ WARNING

Burn and Scald Hazard

Be sure to install the Watts 1170-M2 hot water temperature valve to control water temperature at a safe operating level. Carefully follow the manufacturer’s procedures for installation to ensure accurate water temperature sensing and effective control operation.

Installing the Tempering Valve

Refer to manufacturer's instructions for information on installing the tempering valve.

Mounting the SolVelox on the Storage Tank (residential systems only)

1. Confirm that the P&T valve is on the side of the tank. If it is on the top of the tank, unscrew it and place it in the port on the side of the tank if a side port is available.
2. Use needle nose pliers to remove the heat trap from the hot side of the tank and set it aside.
3. Feed the solar dip tube into the tank, closed end down into the port previously noted as the "hot" port until it seats.
4. Lay the tank down on the ground on top of cardboard or towels.
5. Place the bracket over the SolVelox and place the assembly on the side of the tank. The side of the SolVelox should be 1" to the left of the top electrode cover. The bracket should lie flat on the top of the tank. Scribe the tank to match the bracket location.
6. Using two #10 - 16 x 3/4" self-drilling screws, screw the top of the bracket to the top of the hot water tank. Ensure that the vertical section of the bracket above the heat exchanger is flush with the side of the tank before you drive in the screws.
7. While holding the bracket and the SolVelox firmly against the tank, drive two #10-16 x 3/4" self-drilling screws into the lower section of the bracket just below the heat exchanger and two screws just above the heat exchanger. It is critical that you hold the bracket and SolVelox firmly against

Figure 12 - SolVelox Piping

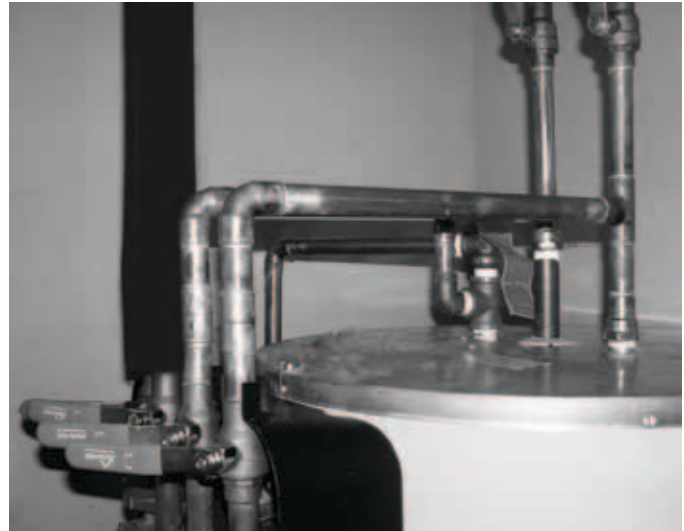

- the tank at this point otherwise it will be loose when you stand the tank upright. Seek assistance to make sure you get the product snug on the tank.
8. Connect a brass tee to the cold water inlet to the tank, drive four #10-16 x 3/4" self-drilling screws into the bracket with two just above and two just below the heat exchanger. **See Figure 12.**
 9. Using 1/2" copper pipe or 1/2" flexible stainless steel pipe, join ball valve D of the SolVelox assembly with a tee connected to the cold inlet. This is the cold water input to the SolVelox. **See Figure 13.**
 10. Using 1/2" pipe and fittings or 1/2" MxF flexible stainless steel pipe, connect the hot water inlet (where you previously installed the solar dip tube) to ball valve C on the SolVelox. This is the hot water return to storage.
 11. Using the flexible stainless steel tubing, attach the expansion tank to the expansion

⚠ WARNING Do not use plastic piping

PEX, PVC and other forms of non-metal pipes will burst at solar temperatures. Only use correctly sized copper or stainless steel pipes in solar heating system on both the solar and potable water loops. All connections to and from the SolVelox must be copper or stainless steel.

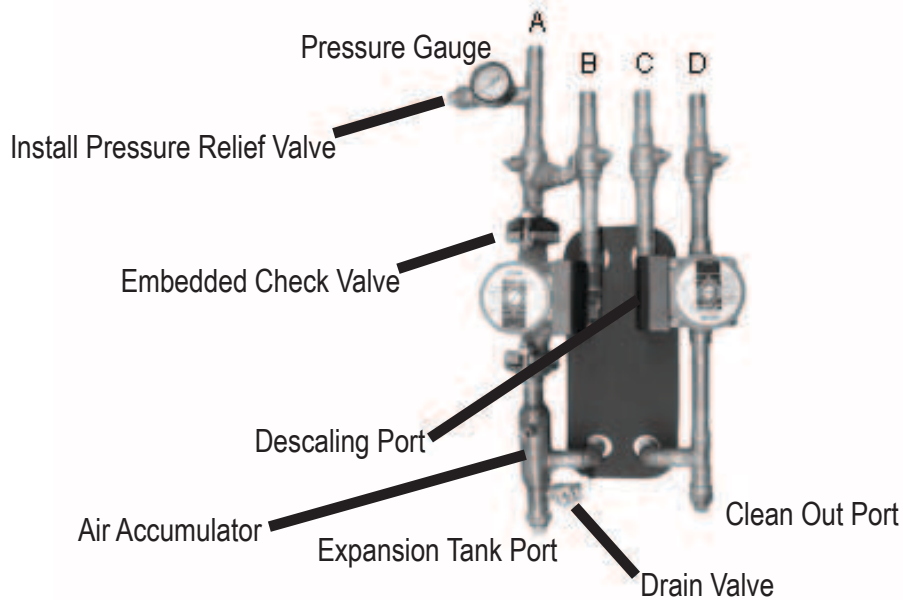
Figure 13 - Glycol Piping Diagram

tank port at the lowest point on the left, below the collector loop pump. Mount the expansion tank to the wall or to the storage tank. **See Figure 14.**

12. Attach a pressure relief valve to the port found at the left side of the pressure gauge. The pressure relief should point towards the ground.
13. Ports A and B on the left are for the collector loop. A pipe coming from the top of the collectors carries the hot antifreeze solution and should be attached to port B.

Figure 14 - Expansion Tank

The pipe leading to the collector attaches to port A directly above the pressure gauge. Connect the collector return to the SolVelox via the second ball valve from the left.

⚠ WARNING Burn and Scald Hazard

Excessive water temperatures could cause explosion, burns, scalding, pressure relief flooding and fitting leaks. Carefully follow the outlined procedures for temperature sensor installation to ensure accurate water temperature sensing and effective control operation.

⚠ WARNING Do not use plastic piping

PEX, PVC and other forms of non-metal pipes will burst at solar temperatures. Only use correctly sized copper or stainless steel pipes in solar heating system on both the solar and potable water loops. All connections to and from the SolVelox must be copper or stainless steel.

Backup Option

Optionally use a 2nd water heater to provide backup heat to the system. The tank with the SolVelox mounted to it will store the solar heated water and will not provide any backup heat. This tank will be referred to as the solar tank.

Mount the SolVelox and plumb the cold water from the street to the solar tank the same way as with a single tank system.

Draw the hot water from the solar tank through a tempering valve and deliver it to the second water heater's (the backup tank) COLD IN port.

Plumb the hot water from the backup tank to the house.

The backup tank will work the same way as a standard water heater, but when there is solar energy available, the tank's thermostat will not signal the heating source to fire.

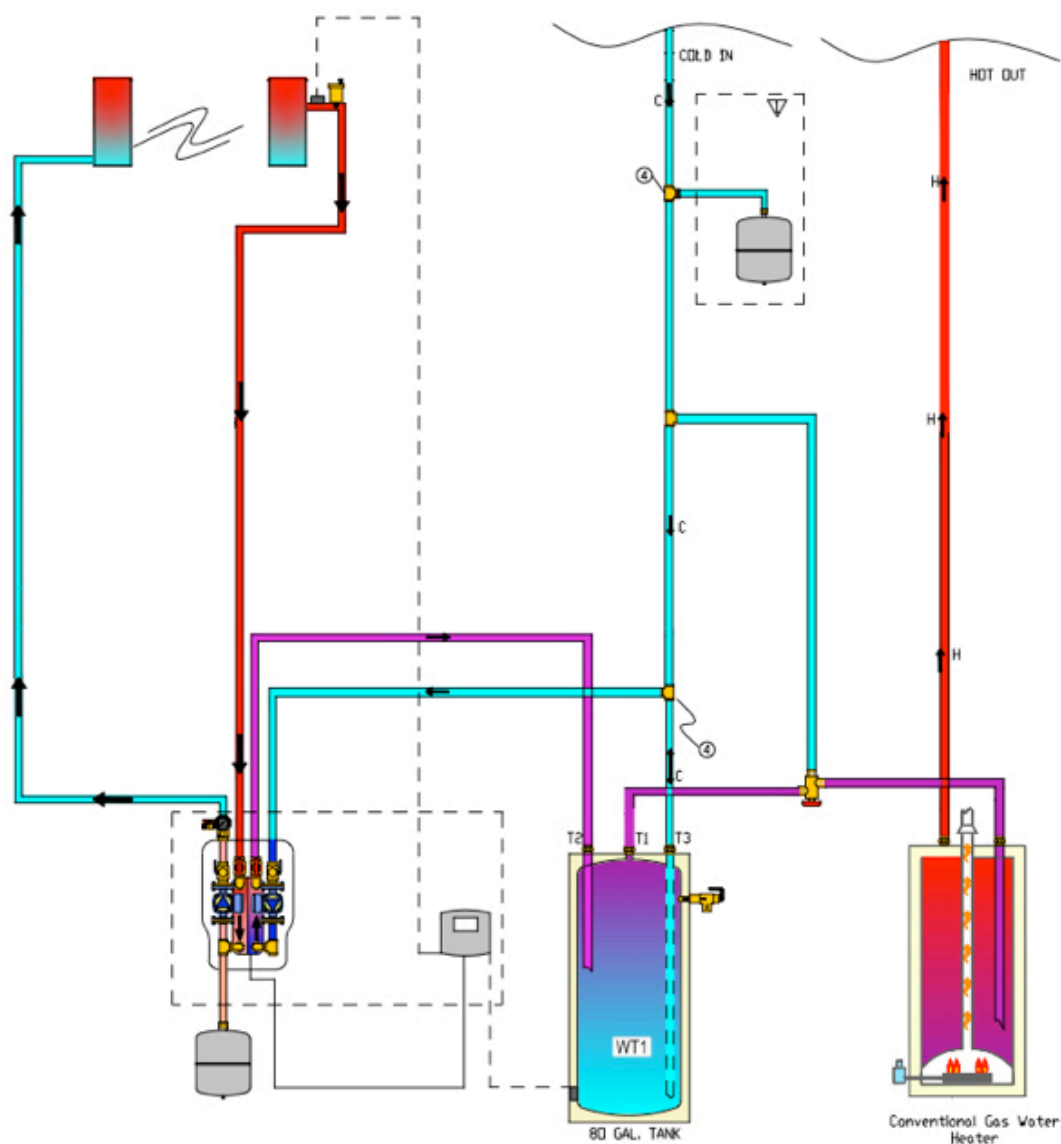
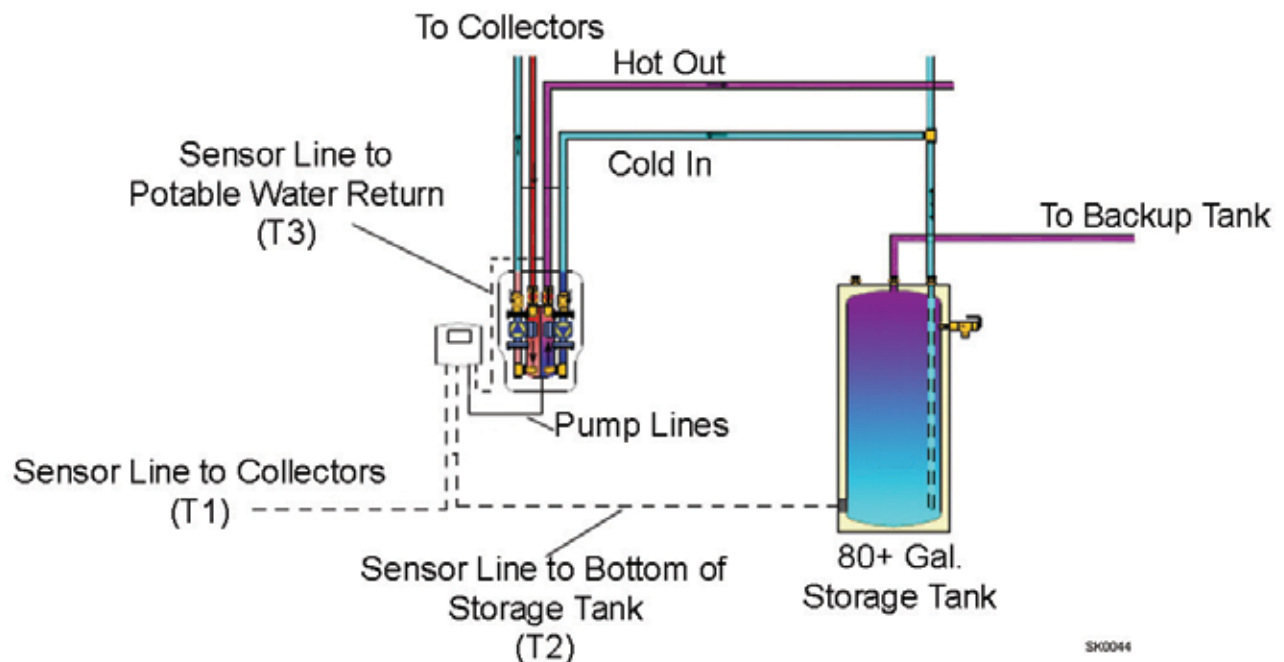

Figure 15 - SolVelox Wiring

Installing the Differential Control

Your Glycol system is automated by the differential control located on the face of the SolVelox cover, as shown in **Figure 15**.

When installing the SolVelox pump package, consult the appliance manufacturer's instructions for additional information on wiring, installing the three sensors, and programming the control. **See also Figure 16**.

1. For the first sensor, 50 feet of 18-gauge sensor wire is included to reach the panel collectors. If you require more wire for your system design, use UV stable (black) 18-gauge sensor wire. This sensor is denoted

Figure 17 - Lower Tank Sensor

- by T1 on the Steca display.
- The lower tank sensor is approximately 5 feet long. Remove the lower access panel shown in **Figure 17** and place the sensor firmly against the interior tank surface. The heavy insulation should hold it securely in place. While the panel is open, turn the bottom heating element to its lowest set point. This sensor is denoted by T2 on the Steca display.
 - The short sensor wire is to be installed on the pipe returning to the backup water heater (potable water return) from the heat exchanger by using a stainless steel screw clamp (**Figure 13, Port C**). It should be placed on the pipe as far from the control as possible. Insulate over the sensor. This sensor is denoted by T3 on the Steca display.

Check Collector Loop for Leaks

- Before the system has been charged, open all shut-off valves on the collector loop.
- Attach a female to male adapter to the drain valve on the bottom left of the SolVelox.
- Open the drain valve and attach the gas test block with the pressure gauge.



- Apply 60 psi of pressure for 15 minutes. Any drop in pressure during that time indicates a leak.
- Find the source of the leak and repair it. Repeat this procedure until the loop holds pressure.

Charging the System

- Flush the system with water to clean out any debris or sediment from the pipes and collectors.
- Connect the outlet of a 1HP pump via a hose to the fill valve, located below the pressure gauge on port A. **Refer to Figure 13.**
- Open the fill valve.
- Open the drain valve, located on the bottom-left corner of the SolVelox (below the pump which leads to port A).
- Connect the drain valve to a bucket.
- Fill the bucket with the appropriate mixture of propylene glycol and water. (see manufacturer's recommendation on the percentage of propylene glycol necessary for freeze protection in your area. We recommend Noble NoBurst.)
- Run the pump. Initially air will vent out of the boiler drain, then a mixture of coolant and air will follow. This process may take 10-30 minutes.
- Continue running the pump until you do not see air bubbles in the coolant.
- Turn off the pump. Let the system sit for two minutes.
- Discharge any air caught in the air trap using the schrader valve located below the collector pump.
- Repeat previous steps until no air is discharged.

12. Close drain valve.
13. Continue charging until it reaches the necessary pressure for the system's configuration. The system requires 15 psi plus 1 psi per 2.3 vertical feet to the top of the collector.
14. Close the fill valve.
15. Turn off and disconnect charging pump.

Operation

Starting the System

1. Confirm that all shut-off valves are fully open.
2. Turn on the system and let it run for 5 minutes.
3. Double-check every component and all pipe runs and fittings for leaks.
4. Adjust upper element of the water heat to a maximum of 120° F for backup heat.
5. Set the high limit on the control to no more than 185° F. Refer to Steca owner's manual.

Check System Operation

Let the system run for 15 minutes on a sunny day, preferably at or near noon. Three temperatures will show on the control: the collector outlet temperature, the bottom of the tank temperature, and the temperature of the water returning to the tank. Typically you should see the temperature at the bottom of the tank vary from 60-80° F (city water temperature) to 185° (high limit set on the control) The water at the top of the tank will be typically higher than the water at the bottom, but should not exceed the high limit set on the control. The Temperature and Pressure Relief Valve on the storage tank is set to 210° F.

Figure 18 - Differential Control



The system will automatically turn on the pumps when the collector temperature is 16° higher than the water at the bottom of the tank. It will shut off the system when the temperature differential is 8° F. Collector temperatures may rise well above 200° F, but the system will not run beyond the high limit set on the control.

A system correctly installed will show the water returning to the tank to be at least 3-10° F warmer than the water at the bottom of the tank.

Please refer to the differential control owner's manual for system operation or adjustments.

Vacation Settings

If the system is not to be used for any extended period of time, the differential control should be set to the HOLIDAY function:

1. Open the menu settings by pressing the "SET" button for approximately two seconds.
2. Press the "DOWN" button until the holiday symbol (umbrella) flashes.
3. Press the "SET" button for approximately two seconds, until the small tick on the holiday symbol appears.

⚠ WARNING Burn Hazard

Exercise extreme caution when draining, as the heat transfer fluid may be dangerously hot.

To Resume Operations:

1. Open the menu settings by pressing the “SET” button for approximately two seconds.
2. Press the “DOWN” button until the holiday symbol (umbrella) flashes.
3. Press the “SET” button for approximately 2 seconds until the small tick on the holiday symbol disappears.
4. See the Steca control manual for more details about the HOLIDAY function.

Emergency Shut Off

1. If there is a leak or other issue requiring the collector loop to be drained, turn the system off by setting the switch on the left side of the differential control to the “OFF” position.
2. Attach a hose to the drain valve on the lower left of the SolVelox. **See Figure 13.**
3. Open the drain valve.

Warning! DO NOT dispose of the heat transfer fluid on the ground or in the water system. Collect it in a container which can be sealed and dispose of it according to the manufacturer’s directions.

Maintenance

Your solar water system requires very little by way of maintenance, but a few regular system checks can extend the life of your system well beyond 20 years.

Freeze Protection

This system is designed to protect itself from freeze damage to temperatures as low as -30°F

as long as the heat transfer fluid in the collectors is at least 40% GRAS propylene glycol. Freeze tolerance limits are based upon an assumed set of environmental conditions. In the event of extreme or prolonged cold weather, protect your system by shutting it down and draining the collector loop as described in the “Vacation Settings” and “Emergency Shut- Off” sections.

⚠ WARNING Burn Hazard

Exercise extreme caution when draining, as the heat transfer fluid may be dangerously hot.

Clear Sediment from Strainer

1. Turn off your solar water system with the switch on the side of the differential control and disconnect the power to the SolVelox by unplugging it from the wall outlet.
2. Close the two shut-off flanges on the right side of the SolVelox. **See Figure 13, ports C & D.**
3. Open the clean out port. See **Figure 13.**
4. Remove any sediment buildup from the clean out port.
5. Close and tighten clean out port.
6. Return shut-off flanges to the open position and reconnect the power to the SolVelox.

Descaling the Heat Exchanger

1. Turn off your solar water system with the switch on the side of the solar differential control and disconnect the power to the SolVelox by unplugging it from the wall outlet.
2. Close the two shut-off valves on the right side of the SolVelox. **See Figure 13, ports C & D.**
3. Unscrew the plugs to open the descaling and clean out ports shown in **Figure 13.**
4. Remove any sediment buildup from the clean out port.

5. Flush the heat exchanger with a weak solution of white vinegar and water.
6. Close and tighten descaling and clean out ports.
7. Return shut-off flanges to the open position and reconnect the power to the SolVelox.

 WARNING Burn Hazard

Exercise extreme caution when draining, as the heat transfer fluid may be dangerously hot.

Change Heat Transfer Fluid

The heat exchange fluid contains buffers which keep the pH of the solution neutral. Heat and time will degrade these buffers, so it is important that you drain the fluid and recharge the system every 3-5 years.

To drain the system:

1. Turn the system off by setting the switch on the left side of the differential control to the "OFF" position.
2. Attach a hose to the drain valve on the lower left side of the SolVelox. **See Figure 13.**
3. Open the drain valve. Dispose of used heat transfer fluid according to manufacturer's directions.

Pumps

The circulation pumps have a life expectancy of 5-10 years. If a pump should require servicing or replacement:

1. Turn off the system with the switch on the side of the differential control.
2. Close all the ball valves at the top of the SolVelox. Leave the system off for several hours until the pumps are completely cooled to room temperature.
3. Solar pumps are flanged so they can be

easily removed by loosening the flange's nuts and bolts. Potable loop pumps use bolts and must be unscrewed.

Service

To obtain service for your SolVelox™, notify the dealer who installed or sold the SolVelox™. In notifying your dealer, provide identification of your SolVelox™, date of purchase (with proof), and the nature of the defect. Ship the SolVelox™ complete in the assembled condition. Use adequate packaging to prevent damage to the pump during shipment.

To obtain the location of the nearest authorized SOLARHOT service and/or distribution facility, call (919) 439-2387 or write to:

SOLARHOT Ltd.

2800 Perimeter Park Dr. Suite A
Morrisville, NC 27560

or on the web at:

<http://www.solarhotusa.com>

email: sales@solarhotusa.com

Warranty Information

Limited Two Year
MANUFACTURER'S WARRANTY
For SolVelox Glycol System

SolarH²Ot Limited warrants to buyer for a period of twenty-four (24) months from the date of sale that the equipment at the time of shipment will be free from defects of design, material, and workmanship.

- If any defects or malperformance occur during the warranty period, SOLARHOT's sole obligation shall be limited to alteration, repair, or replacement at SOLARHOT's expense, F.O.B. Factory, of parts or equipment, which upon return to SOLARHOT and upon SOLARHOT's examination prove to be defective.
- Equipment and accessories not manufactured by SOLARHOT are warranted only to the extent of and by the original manufacturers' warranty.
- SOLARHOT shall not be liable for damage or wear to equipment caused by abnormal conditions, acts of God, failure to properly prime or to operate equipment without flow or caused by corrosives, abrasives or foreign objects.

THE FOREGOING WARRANTY IS EXCLUSIVE AND IN LIEU OF ALL OTHER WARRANTIES, WHETHER EXPRESSED OR IMPLIED, INCLUDING ANY WARRANTY OF MERCHANTABILITY OR FITNESS FOR ANY PARTICULAR PURPOSE.

IN NO EVENT SHALL SOLARHOT BE LIABLE FOR CONSEQUENTIAL OR INCIDENTAL DAMAGES.

Limited Ten Year
MANUFACTURER'S WARRANTY
For SolarHot Platinum Collectors

SolarH²Ot Limited warrants to buyer for a period of ten (10) years from the date of sale that the equipment at the time of shipment will be free from defects of design, material and workmanship.

- If any defects occur during the warranty period, SOLARHOT's sole obligation shall be limited to alteration, repair or replacement at SOLARHOT's expense, F.O.B. Factory, of parts or equipment, which upon return to SOLARHOT and upon SOLARHOT's examination prove to be defective.
- Equipment and accessories not manufactured by SOLARHOT are warranted only to the extent of and by the original manufacturers' warranty.
- SOLARHOT shall not be liable for damage or wear to equipment caused by abnormal conditions, acts of God, failure to properly prime or to operate equipment without flow or caused by corrosives, abrasives or foreign objects.

Please note that the warranty does not apply to conditions or damage caused by:

1. A failed component or part that is not a part of the SOLARHOT collector.
2. Freezing conditions.
3. Misuse, abuse, neglect, accident, or alteration.
4. Cosmetic discoloration of the frame-wall, absorber plate, or glazing over time.
5. Glass breakage.
6. The introduction of harmful chemicals, caustic fluids, or liquids deleterious to copper tubing, including improperly applied or maintained heat transfer fluids and chlorinated water. The use of SOLARHOT collectors for pool or spa heating is not covered by this warranty unless the pool or spa water is isolated from the collector through the use of a heat exchanger.
7. Heat transfer fluids other than distilled water or propylene glycol are used.
8. Propylene glycol pH levels exceeding 10 or falling below 8.
9. Stagnation in excess of 30 days.
10. Excessive pressure.
11. Excessive flow rates.
12. Improper plumbing configurations.
13. Clouding or condensation naturally resulting from temporary intrusions of moisture into the collector.
14. Acts of God.
15. Installation methods, including mounting, that do not conform to relevant national, state, or local codes and ordinances, good industry practices, or current applicable SOLARHOT manuals, diagrams, or installation instructions.

THE FOREGOING WARRANTY IS EXCLUSIVE AND IN LIEU OF ALL OTHER WARRANTIES, WHETHER EXPRESSED OR IMPLIED, INCLUDING ANY WARRANTY OF MERCHANTABILITY OR FITNESS FOR ANY PARTICULAR PURPOSE.

IN NO EVENT SHALL SOLARHOT BE LIABLE FOR CONSEQUENTIAL OR INCIDENTAL DAMAGES.

Field labor to repair or replace any defective SOLARHOT product is reimbursable as follows:

Year 1: \$100 per collector

Year 2-5: \$75 per collector

Year 6-10: \$50 per collector

After one (1) year of warranty, freight and shipping costs are the responsibility of the owner.

Congratulations on the installation of your SOLARHOT SolVelox System. Correctly installed and maintained, your system should provide you with many years of uninterrupted solar hot water. The solar collectors are designed to last 25-35 years, electric water heaters 10-20, pumps, controls and valves 5-10. Local water quality and usage will greatly affect life expectancies.

Parts List:

SOLARHOT SolVelox Glycol

S-SV-G100P64, S-SV-G100P52, S-SV-GS64, S-SV-GS40, S-SV-GP64-120, S-SV-GP80-120, S-SV-GE32, S-SV-GE40, S-SV-GS32, S-SV-GS40, S-SV-GE52, S-SV-GE64, S-SV-GS64, S-SV-GE64-120, S-SV-GE80-120, S-SV-GS80-120, S-SV-GE78-120, S-SV-GE96-120, S-SV-GEHC58, S-SV-GEHC87, ZASP-2FP, ZASP-3FP, ZASP-4FP, S-SV-GUMA64, S-SV-GUMA64-120, S-SV-GUMA40, S-SV-GUMA40-120

Solar Collector:

S-SC-126P40, S-SC-126P32, S-SC-126P40, S-C-771D26, S-C-771D32, S-C-771D40, S-C-126S26, S-C-126S32, S-C-126S40, FP.1.20.0.HE sc, Helicol HC, SLAR-32, SLAR-40

Solar Storage Tank:

80 gallon tank	120 gallon
Whirlpool EE3Z80HD055V	Rheem 81VR120TC-1
American Premier E62-80H-045DV	Lochinvar FTA120K
Rheem 81VR80TC-1	American E62-119R-045D
Lochinvar FTA082K	Bradford White MS120R6S
Bradford White MS800R6SS	AO Smith SUN 120
AO Smith ProMax SUN80	

Pumps:	Armstrong	Wilco	Taco
Collector Loop Glycol	Astro 30B	Star 16B	006B
Collector Loop Drainback	Astro 70B	Star 32B	009B
Tank Loop	Astro 20B	Star 5B	003B

Controller: Steca Differential Control TR 0301U, requires PT1000 probe or lug replacement sensors

Heat Exchanger: SOLARHOT P-HX-210512

System operating parameters:

- Pressure on a glycol system should be between 25-30 psi
- Flow meter should read about 5 gpm on the collector loop and 3.5 on the tank loop

Gas Backup Systems:

S-SV-GP64G, S-SV-GP80G, S-SV-G52G, S-SV-GE52G, S-SV-GE64G, S-SV-GE80G, S-SV-GS64, S-SV-GE96G-120

Solar Collector: S-SC-126P40, S-SC-126P32, S-SC-126P40, S-C-771D26, S-C-771D32, S-C-771D40, S-C-126S26, S-C-126S32, S-C-126S40

Solar Storage Tank:

80 gallon tank	120 gallon
Whirlpool EE3Z80HD055V	Rheem 81VR120TC-1
American Premier E62-80H-045DV	Lochinvar FTA120K
Rheem 81VR80TC-1	American E62-119R-045D
Lochinvar FTA082K	Bradford White MS120R6S
Bradford White MS800R6SS	AO Smith SUN 120
AO Smith ProMax SUN80	

Pumps:	Armstrong	Wilco	Taco
Collector Loop Glycol	Astro 30B	Star 16B	006B
Collector Loop Drainback	Astro 70B	Star 32B	009B
Tank Loop	Astro 20B	Star 5B	003B

Controller: Steca Differential Control TR 0301U, requires PT1000 probe or lug replacement sensors

Heat Exchanger: SOLARHOT P-HX-210512

Evacuated Tube Systems

SOLARHOT SolVelox Glycol ET

S-SV-G-ET30, S-SV-G100ET, S-SV-G-ET30-120, S-SV-GET60-120, S-SV-GASWS52B80, SV-G2ASW52B120, S-SV-GASWS58A-30, S-SV-GASWS58A-25, S-SV-GASWS58A

Solar Collector: Apricus AP-30, American Solar Works ASW52B, ASW52B Stretch, -58A-30, -58A

Solar Storage Tank:

80 gallon tank	120 gallon
Whirlpool EE3Z80HD055V	Rheem 81VR120TC-1
American Premier E62-80H-045DV	Lochinvar FTA120K
Rheem 81VR80TC-1	American E62-119R-045D
Lochinvar FTA082K	Bradford White MS120R6S
Bradford White MS800R6SS	AO Smith SUN 120
AO Smith ProMax SUN80	

Pumps:	Armstrong	Wilco	Taco
Collector Loop Glycol	Astro 30B	Star 16B	006B
Collector Loop Drainback	Astro 70B	Star 32B	009B
Tank Loop	Astro 20B	Star 5B	003B

Controller: Steca Differential Control TR 0301U, requires PT1000 probe or lug replacement sensors

Heat Exchanger: SOLARHOT P-HX-210512

WATTS Series 1170-M2 Installation Instructions

Hot Water Temperature Control Valves

IMPORTANT: Valve should be installed and adjusted by a licensed contractor in accordance with local codes and ordinances. Further, this valve should be installed in a location where it is accessible for cleaning, service or adjustment.

INSTALLATION

(Valve should be installed by a licensed contractor.)

1. Close both the hot and cold water shutoff valves upstream nearest to the intended installation.
2. Bleed the remaining water from the system.
3. Connect the water supply to valve as shown in Figure 1 or 2, depending on the application. Supply piping must be flushed clean before making connections to the valve.

IMPORTANT!: To prolong the life of the Model 1170-M2, L1170-M2 valve, it is recommended that it be trapped as shown: i.e. the hot water inlet to the 1170-M2 valve should be 8" – 12" (200 – 305mm) below the hot water supply feed.

4. Valve can be installed in any position. Note: the inlet hot supply is to be connected to the "H" side of the valve, the cold supply side to the "C" side and the mixed water outlet to the "M" side.
5. Make sure union nuts are placed over tailpieces prior to soldering or threading to pipe.
6. For valves with Quick-Connect tailpieces refer to "Quick-Connect Installation" instructions.

Note: To prevent damage to valve from excessive heat during soldering, remove unions and gaskets from valve body prior to soldering.

7. After soldering, flush piping and install valve using filter washer on hot and cold water inlet and fiber washer on the mixed water outlet.
8. Start-up: Open cold water supply, then hot water supply. Inspect for leaks.

Adjust temperature to desired setting (see Temperature Adjustment Section).

Temperature Adjustment

1. Let water flow for at least two minutes to allow supply temperature to stabilize.
2. Calibrate the mixed water outlet temperature by placing a thermometer in the mixed water stream.
3. To adjust the setting of the valve, loosen locking cap screw with hex wrench, see Figure 3. Cap must be lifted 1/4" to adjust temperature. To increase the temperature, turn counterclockwise. To decrease temperature turn clockwise.
4. Lower handle and tighten screw.

Check outlet temperature.

†WARNING

Watts Hot Water Temperature Control Valves cannot be used for tempering water temperature at fixtures. Severe bodily injury (i.e. scalding or chilling) and/or death may result depending upon system water pressure changes. ASSE Standard 1016, ASSE 1070 listed devices such as Watts Model L111 or Series USG, or MMV should be used at fixtures to prevent possible injury. The Watts Hot Water Temperature Control Valves are designed to be installed at or near the boiler or water heater. They are not designed to compensate for system pressure fluctuations and should not be used where ASSE 1016 devices are required. These WATTS valves should never be used to provide "anti-scald" or "anti-chill" service. When installing the Series 1170-M2 valves in a radiant heat application, the components of the radiant heat system must be of materials with a construction capable of withstanding the high limit output temperatures of the heating boiler. If you are uncertain as to the product's adaptability for your application, please consult an authorized representative before installing or using the product.

Quick-Connect Installation

To Connect

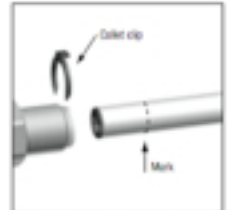
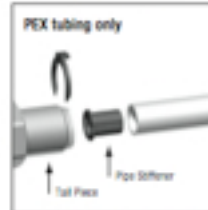
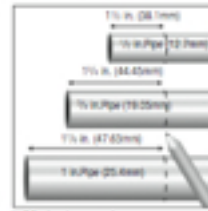

To Disconnect

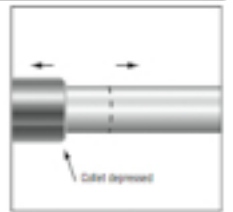

MATERIAL SAFETY DATA SHEET

NOBURST® -100

1. General

Date Prepared: May 2, 2000

Trade Name NOBURST -100

Manufacturer's Name THE NOBLE COMPANY

Address 7300 Enterprise Drive Spring Lake, MI 49456

Emergency Telephone Number (231) 799-8000

Telephone Number for Information (231) 799-8000

Synonyms None

Chemical Family Glycols

Generic Name Monopropylene Glycol

DOT Hazardous Material Proper Shipping Name Not regulated;

DOT Hazard Class; DOT Packing Group; DOT Reportable Quantity (Based on Material); UN/NA ID No. ;Not regulated orNot applicable

CAS No. (See Section 9 — Components) MSDS Class F

2. Summary of Hazards

Signal Word CAUTION

Physical Hazards Aqueous solutions may produce flammable vapors; Slightly combustible liquid

Acute Health Effects (Short-Term): No inhalation hazard identified from data available; Slight eye irritant; No ingestion hazard identified from data available; No skin irritation hazard identified from data available; No skin absorption hazard identified from data available

Chronic Health Effects (Long-Term) : No chronic health hazards are expected to occur from anticipated conditions of normal use of this material

3. Fire and Explosion

Flash Point: AP 2280 F (PMCC)

Autoignition Temperature: AP 700° F

Flammable Limits (at Normal Atmospheric Temp and Pressure): Lower: AP 2.4 (% vol in air) Upper: AP 17.4 (% vol in air)

Fire and Explosion Heat Hazards from fire can generate flammable vapor. When mixed with air and exposed to ignition source, vapors can burn in open or explode if confined. Vapors may travel long distances along the ground before igniting and flashing back to vapor source. Fine sprays mists may be combustible at temperatures below normal flash point. Aqueous solutions containing less than 95% propylene glycol by weight have no flash point as obtained by standard test methods. However aqueous solutions of propylene glycol greater than 22% by weight, if heated sufficiently, will produce flammable vapors. Always drain and flush systems containing propylene glycol with water before welding or other maintenance.

Extinguishing Media: Alcohol type foam; CO2; Dry chemical

Extinguishing Media Use waterspray/waterfog for cooling

Special Firefighting Procedures: Do not enter fire area without proper protection. Fight fire from a safe distance/protected location. Heat may build enough pressure to rupture closed containers/spreading fire/increasing risk of burns/injuries. Use water spray/fog for cooling. Avoid frothing/steam explosion. Burning liquid may float on water. Although water-soluble, may not be practical to extinguish fire by water dilution. Notify authorities immediately if liquid enters sewer/public waters.

4. Health Hazards

Summary of Acute Hazards: Not expected to present a significant acute health hazard upon short-term exposure.

Inhalation No significant signs or symptoms indicative of any adverse health hazard are expected to occur as a result of inhalation exposure.

Eye Contact May cause minor eye irritation.

Skin Absorption No significant signs or symptoms indicative of any health hazard are expected to occur as a result of skin absorption exposure.

Skin Irritation No significant signs or symptoms indicative of any adverse health hazard are expected to occur as a result of skin exposure. Ingestion No significant signs or symptoms indicative of any health hazard are expected to occur as a result of ingestion.

Summary of Chronic Hazards No adverse chronic health effects are expected from anticipated conditions of normal use of this material unless aerosol is generated.

Special Health Effects This material or its emissions may aggravate pre-existing eye disease.

5. Protective Equipment and Other Control Measures

Respiratory No special respiratory protection is recommended under anticipated conditions of normal use with adequate ventilation.

Eye Eye protection such as chemical splash goggles and/or face shield must be worn when possibility exists for eye contact due to splashing or spraying liquid, airborne particles, or vapor. Contact lenses must be worn.

Skin Not normally considered a skin hazard. Where use can result in skin contact, practice good personal hygiene. Wash hands and other exposed areas with mild soap and water before eating, drinking, smoking, and when leaving work.

Engineering Controls No special ventilation is recommended under anticipated conditions of normal use beyond that needed for normal comfort control.

Other Hygienic Practices Use good personal hygiene practices. Wash hands before eating, drinking, smoking, or using toilet facilities. Promptly remove soiled clothing/wash thoroughly before reuse. Shower after work using plenty of soap and water.

Other Work Practices No special work practices are needed beyond the above recommendations under anticipated conditions of normal use.

6. Occupational Exposure Limits

No occupational exposure limit(s) have been established for this material or its components

7. Emergency and First Aid

Inhalation Not expected to present a significant inhalation hazard under anticipated conditions of normal use.

Eye Contact In case of eye contact, immediately rinse with clean water for 20-30 minutes. Retract eyelids often. Obtain emergency medical attention if pain, blinking, tears or redness persists.

Skin - Contact Not expected to present a significant skin hazard under anticipated conditions of normal use.

Ingestion Not expected to present a significant ingestion hazard under anticipated conditions of normal use.

Physician's Emergency Medical Treatment Procedures Treat symptomatically. Treatment of overexposure should be directed at the control of symptoms and the clinical condition of the patient. After adequate first aid, no further treatment is required unless symptoms reappear.

Physician's Detoxification Procedures No detoxification information available.

8. Spill and Disposal

Precautions if Material is Spilled or Released

May contaminate water supplies/pollute public waters. Evacuate/limit access. Equip responders with proper protection. Prevent flow to sewer/public waters. Stop release. Notify fire and environmental authorities. Restrict water use for cleanup. Slippery walking. Spread granular cover. Impound/recover large land spill. Soak up small spills with inert solids. Use suitable disposal containers. On water, material is soluble and may float or sink. May biodegrade. Contain/collect rapidly to minimize dispersion. Disperse residue to reduce aquatic harm. Report per regulatory requirements.

Waste Disposal Methods

Landfill solids at permitted sites. Use registered transporters. Burn concentrated liquids, diluting with clean, low viscosity fuel. Avoid flameouts. Assure emissions comply with applicable regulations. Dilute aqueous waste may biodegrade. Avoid overloading/ poisoning plant biomass. Assure effluent complies with applicable regulations. Contaminated product, soil, water, container residues and spill cleanup materials should not be designated as hazardous wastes.

9. Components

Propylene Glycol 57-55-6 N/P

Dipotassium Phosphate 7758-11-4 N/P

###1=U.S. National Toxicological Program 2=International Agency for Research on Cancer 3=U.S. Occupational Health and Safety Administration 4=American Conference of Governmental Industrial Hygienists 9=Other N/P=No Applicable Information Found

10. Component Health Hazards

Propylene Glycol Slight eye irritant

11. Additional Toxicological Information

Propylene Glycol

High concentrations of Propylene Glycol in water when held in contact with human skin under closed conditions have been reported to cause skin irritation (Cosmetics and Toiletries 99:83-91, 1984). The authors attribute the observations to a sweat retention reaction by skin. No reactions were observed in open patch tests with human subjects. One literature report indicates rare eczematous skin reactions and even more rarely an allergic skin reaction from exposure to Propylene Glycol (Anderson and Starr, Hautzart 33 (1) 1982).

Material: No additional toxicology information is available for this material.

12. Physical and Chemical Data

Boiling Point: AP 370° F (at 760 mm Hg) Viscosity: AP 46 CPS (at 770F) (Brookfield) Dry Point: AP 374° F

Freezing Point AP > -50° F Vapor Pressure AP 0 mm Hg (at 68° F) Volatile Characteristics Slight

Specific Gravity: AP 1.04 (H₂O=1.0 at 39.2° F) Vapor Specific Gravity: AP 2.6 (Air =1.0 at 60-90° F) Solubility in Water: Complete (In All Proportions)

pH: 9 Hazardous Polymerization: Not Expected to Occure Stability: Stable

Other Chemical Reactivity: Reacts with strong oxidizing agents

Other Physical and Chemical Properties: Hygroscopic

Appearance and Odor Pink; Slightly viscous liquid; Little or no odor

Conditions to Avoid: High temperatures, oxidizing conditions

Materials to Avoid: Strong oxidizing agents

Hazardous Decomposition Products: Incomplete combustion may produce carbon monoxide and other toxic gases

13. Hazards Rating Information

National Fire Protection Association Health = 0 Flammability = 1 Reactivity = 0 Special Hazard — None

Ratings have been based on available component information from the National Fire Protection Association.

National Paint and Coatings Association: Hazardous Material Information System (HMIS): Health = 0 Flammability = 1 Reactivity = 0

Ratings have been generated according to criteria specified in the National Paint and Coatings Association Implementation Manual based on component information available.

14. Additional Precautions

Handling and Storage Procedures Hygroscopic. Use dry nitrogen or low dew point air for tank padding. Keep drums tightly closed to prevent contamination. Store at 65-90o F.

Decontamination Procedures: Isolate, vent, drain, wash and purge systems or equipment before maintenance or repair. Wear recommended personal protective equipment.

Observe precautions pertaining to confined space entry.

15. Regulatory Information

Federal: The following is the Toxic Substances Control Act (TSCA) Chemical Substance Inventory Status of the components of this material

listed in Section 9 –Components:

Propylene Glycol 57-55-6 Listed –Non Confidential

Dipotassium Phosphate 7758-11-4 Listed - Non Confidential

Superfund Amendments and Reauthorization of 1988 (SARA), Title III

-Section 302/304

Requires emergency planning based on ‘Threshold Planning Quantities’(TPQs), and release reporting based on Reportable Quantities (RQs) of ‘Extremely Hazardous Substances’ (EHS) listed in Appendix A of 40 CFR 355. There are no components of this material with known CAS numbers which are on the EHS list.

-Section 311 & 312

Based upon available information, this material and/or components are not classified as any of the specific health and/or physical hazards defined by Section 311 & 312.

-Section 313

The material does not contain any chemical components with known CAS numbers that exceed the De Minimis reporting levels established by SARA Title III, Section 313 and 40 CFR 372. Comprehensive Environmental Response, Compensation and Liability Act (CERCLA) No chemicals in this material with known CAS numbers are subject to the reporting requirements of CERCLA.

OSHA Regulations ‘Chemical-specific’ U.S. Occupational Safety and Health Administration (OSHA) regulations (1910.1002 to 1910.1050) presented under 29 U.S. Code of Federal Regulations (CFR) 1910 do not apply to this material or its components.

Other EPA Regulations No additional information available

Department of Transportation (DOT) Other than the normal shipping instructions and information given in this MSDS, there is no other specific U.S. Department of Transportation (DOT) regulations governing the shipment of this material.

State Regulations:

California Safe Drinking Water and Toxic Enforcement Act of 1988 –Proposition 65 This material is not known to contain any chemicals currently listed as carcinogens or reproductive toxins under California Proposition 65 at levels which would be subject to the proposition. California South Coast Air Quality Management District (SCAQMD) Rule 443.1 (VOC’s) A Volatile Organic Compound (VOC) is any volatile compound of carbon excluding methane, carbon monoxide, carbonic acid, metallic carbides or carbonates, ammonium carbonate, 1,1,1-trichloroethane, methylene chloride, (FC-23), (CFC-113), (CFC-12), (CFC-11), (CFC-22), (CFC-114), and (CFC-115). By this definition, this is a VOC material.

Massachusetts Right to Know Substance List (MSL) [105 CMR 670.000]

Extraordinarily Hazardous Substances (MSL-EHS) must be identified when present in materials at levels greater than state specified criterion. The criterion is $\geq 0.0001\%$. Hazardous Substances (MSL-HS) on the MSL must be identified when present in materials at greater than the state specified criterion. The criterion is $\geq 1\%$. Components with CAS numbers present in this material, at levels specified in Section 9 –Components, do not require reporting under the statute.

New Jersey Registration

The New Jersey, Registry 3, Registration law does not apply to this material, as none of its components are trade secrets.

Pennsylvania Right to Know Hazardous Substance List

Hazardous Substances (PA-HS) must be identified when present in materials at levels greater than the state specified criterion. The criterion is $\geq 1\%$. Components with CAS numbers in this material at a level which could require reporting under the statute are:

Propylene Glycol 57-55-6

Dipotassium Phosphate 7758-11-4

Special Hazardous Substances (PA-SHS) must be identified when present in materials at levels greater than the state specified criterion. The criterion is $\geq 0.01\%$. Environmental Hazards (PA-EH) must be identified when present in material at levels greater than the state specified criterion. The criterion is $\geq 0.01\%$. Components with CAS numbers in this material, at levels specified in Section 9 –Components, do not require reporting under the statute.

Regulatory Advisory

If you reformulate or further process this material, you should consider re-evaluation of the regulatory status of the components listed in this sheet.

16. General Comments

This document is generated for the purpose of distributing health, safety, and environmental data. It is not a specification sheet nor should any displayed data be construed as a specification.

DISCLAIMER OF LIABILITY:

The information in this MSDS was obtained from sources which we believe are reliable. However, the information is provided without any warranty, express or implied, regarding its correctness. The conditions or methods of handling, storage, use or disposal of the material are beyond our control and may be beyond our knowledge. For this and other reasons, we do not assume responsibility and expressly disclaim liability for loss, damage or expense arising out of or in any way connected with the handling, storage, use or disposal of the material.

This MSDS was prepared and is to be used only for this material. If the material is used as a component in another material, this MSDS information may not be applicable.

This document is generated for the purpose of distributing health, safety, and environmental data. It is not a specification sheet nor should any displayed data be construed as a specification. Some of the information presented and conclusions drawn herein are from sources other than direct test data on the material itself.

THE INFORMATION PRESENTED HEREIN, WHILE NOT GUARANTEED, WAS PREPARED BY TECHNICALLY KNOWLEDGEABLE PERSONNEL AND TO THE BEST OF OUR KNOWLEDGE IS TRUE AND ACCURATE. IT IS NOT INTENDED TO BE ALL-INCLUSIVE, AND THE MANNER AND CONDITIONS OF USE AND HANDLING MAY INVOLVE OTHER OR ADDITIONAL CONSIDERATIONS. CONSULT THE NOBLE COMPANY FOR FURTHER INFORMATION. <?>

GLYCOL SYSTEM



SOLARHOT Ltd.

2800 Perimeter Park Dr. Suite A · Morrisville, NC 27560 · Phone: 919.439.9061
Fax 919.573.0791 · Email: sales@solarhotusa.com
www.solarhotusa.com