

# AM-1 1070 Series Proportional Thermostatic Mixing Valve

PATENTED, WITH DUAL ASSE 1070 AND 1017 CERTIFICATION, IAPMO AND CSA LISTING IN ONE VALVE

**PRODUCT DATA**

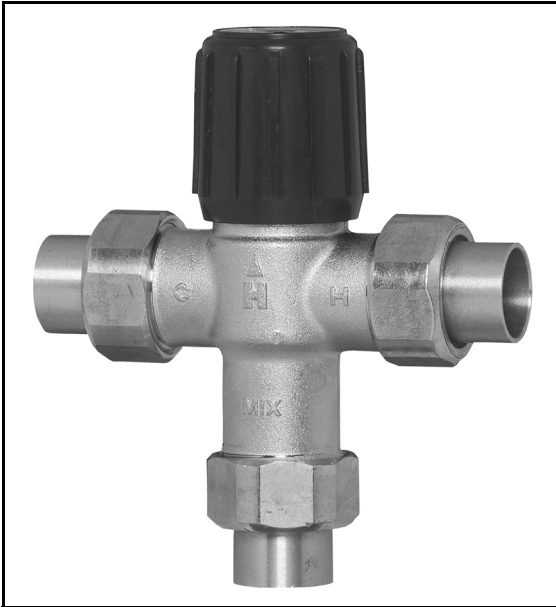

### PRODUCT INFORMATION

- Nickel plated/bronze construction, EPDM O-rings.
- Straight thru design (hot and cold at same level).
- Maximum hot water supply temperature 212° F (100° C).
- Designed for easy maintenance and element replacement.
- Sweat, Threaded, CPVC, PEX and Compression connections available.
- Teflon® coated spool and body to prevent mineral buildup and extend life.
- Minimum required temperature difference between hot and mix 3° F (1.5° C).
- Made in the USA.

### SPECIFICATIONS

**Temperature Range:** 70° - 120° F (21° - 49° C).

**Maximum Working Pressure:** 125 psi (862 kPa).

**Maximum Flow:** 10 Gpm (37.9 Lpm).

**Minimum Flow:** 0.5 Gpm (1.9 Lpm).

**Agency Approval:** CSA® IAPMO® and ASSE

**Additional Information:** Dual Certification ASSE 1070 and ASSE 1017  
 Constant water temperature under different operating conditions.  
 Proportional valve (simultaneous control of hot and cold water).  
 Thermal shock protection at correct setting.  
 Lockable hand wheel (loosen top screw and lift hand wheel to adjust mixing valve).

### Contents

Specifications .....	1
Product Information .....	1
Valve Adjustment .....	2
Application Information .....	2
Ordering Information .....	2
Installation .....	3
Operation .....	4
Valve Maintenance .....	5
Typical Specification .....	6



62-3098-02

## VALVE ADJUSTMENT

### Temperature Setting Procedure

It is possible to limit the temperature range. To use this feature:

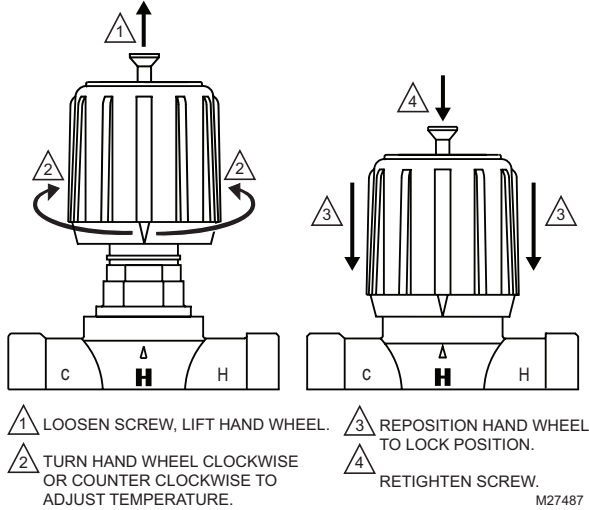

## APPLICATION INFORMATION

For domestic hot water applications the mix temperature upper limit must not exceed a temperature of 120° F (49° C) to prevent scalding.

### ASSE 1070 Applications-Point of Use:

Individual showers, baths or a combination of: automatic faucets, nursing homes, public facilities and wherever ASSE 1070 valves are required.

Table 1. AM-1 1070 Series Union Connections

Model Number	Conn. Size in.	C <sub>v</sub> in.	Union Conn.	A in. (mm)	B in. (mm)	C in. (mm)
AM100C1070-US-1	1/2	1.8	Sweat	3.2 (81)	2.7 (69)	4.4 (112)
AM101C1070-US-1	3/4				2.9 (73)	4.9 (124)
AMC102C1070-US-1	1				3.5 (89)	6.1 (155)
AM100C1070-UT-1	1/2		Threaded		2.9 (73)	4.8 (122)
AM101C1070-UT-1	3/4				3.8 (97)	6.5 (165)
AM102C1070-UT-1	1				3.9 (99)	7.0 (178)
AM100C1070-UCPVC-1	1/2		CPVC		3.0 (76)	5.1 (130)
AM101C1070-UCPVC-1	3/4				3.0 (76)	5.1 (130)
AM100C1070-UPEX-1	1/2				PEX	3.1 (79)
AM101C1070-UPEX-1	3/4		3.1 (79)			5.3 (135)
AM100C1070-UC-1	1/2		Compression		3.9 (99)	6.6 (168)
AM101C1070-UC-1	3/4				4.1 (104)	7.2 (183)

## ORDERING INFORMATION

When purchasing replacement and modernization products from your TRADELINE® wholesaler or distributor, refer to the TRADELINE® Catalog or price sheets for complete ordering number.

If you have additional questions, need further information, or would like to comment on our products or services, please write or phone:

1. Your local Honeywell Automation and Control Products Sales Office (check white pages of your phone directory).
2. Honeywell Customer Care  
1885 Douglas Drive North  
Minneapolis, Minnesota 55422-4386

In Canada—Honeywell Limited/Honeywell Limitée, 35 Dynamic Drive, Toronto, Ontario M1V 4Z9.

International Sales and Service Offices in all principal cities of the world. Manufacturing in Australia, Canada, Finland, France, Germany, Japan, Mexico, Netherlands, Spain, Taiwan, United Kingdom, U.S.A.

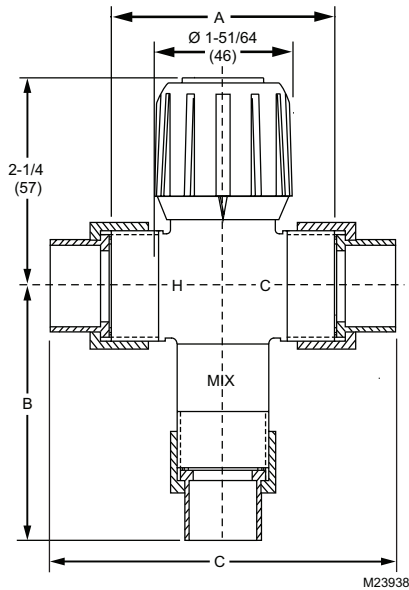

Fig. 1. Dimension Diagram

## INSTALLATION

**NOTE TO INSTALLER:** This product should be installed by a qualified individual, in accordance with local codes and ordinances. It is the responsibility of the installer to properly select, install and adjust these devices as specified in these instructions. For installations, which require compliance with Building/Mechanical/Plumbing Codes, the appropriate AM-1 Series Valve must be chosen and installed and the discharge temperature set and locked according to these instructions. These models shall be used to supply water to tubs, showers, bathing facilities and other outlets. These valves should be installed where they will be accessible for cleaning, servicing or adjustment.

**NOTE:** Pressure difference between Hot and Cold ports should not exceed 10 psi (68.9 kPa).

### Installation of Union Sweat, CPVC and PEX Connections

- Union sweat connections, if used, should be soldered prior to assembly to the valve, or without the sealing gasket or optional check valve present. After the joint has cooled, the sealing gasket and/or check valves may be installed.
- CPVC fittings are limited to a system maximum temperature of 180° F (82° C) and 100 psi (689 kPa).
- Pex fitting and crimp ring (provided by Installer) are designed to meet ASTM F1807 requirements.
- Pex tubing used with PEX fittings must meet ASTM F876 requirements.

## ASSE 1070 Applications:

These AM-1 1070 models can be installed in any position consistent with the intended use. The AM-1 1070 shall be installed as shown in Fig. 2. Check valves, as indicated, may be installed to prevent migration of hot water into the cold branch and cold water into the hot branch through the AM-1 1070 Valve. Sweat union connections (if used) should be soldered prior to assembly to the valve or without the sealing gasket or optional plastic check valve present. After the joint has cooled, the sealing gasket and / or check valves may be installed.

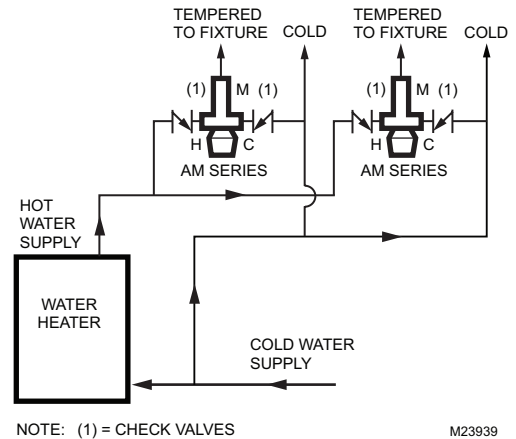

Fig. 2. AM Series ASSE 1070 - Two Handle Fixtures

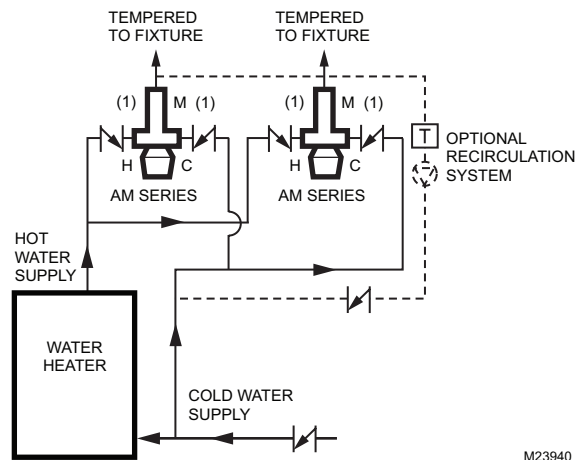

Fig. 3. AM Series ASSE 1070 - Handless Fixtures

## Domestic Water Mixing (Tempering) (ASSE 1017) (Source of Hot Water)

Use when water temperature produced by heater is hotter than designed at point of use. Many codes require that water supplied to the system be limited to 120° F (49° C) max.

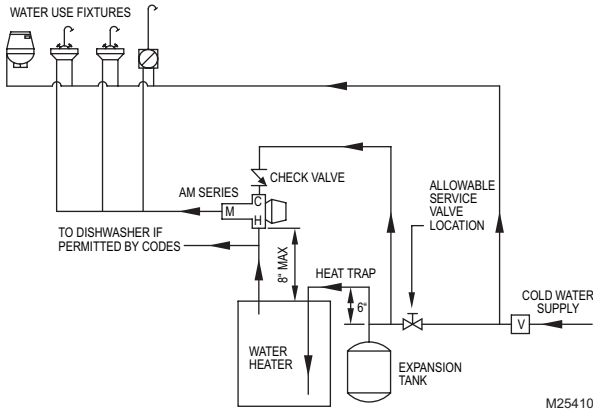

Fig. 4. Water Heater Without Recirculation

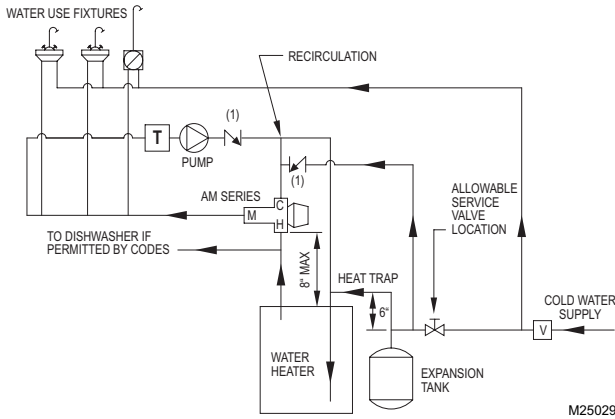

Fig. 5. Water Heater With Recirculation

### SYMBOLS

1 = Check Valve/Flow Check

2 = Alternate Pump Location

V = Any device which turns the domestic water system into a closed system such as; backflow preventers, check valves or pressure reducing valves.

T= Honeywell Aquastat

### NOTES:

- “V” is optional depending on local codes. If a “V” type valve is used, it is mandatory that a thermal expansion tank be installed as shown. Otherwise, dangerously high pressure could result or water heater safety relief valve will frequently expel water. If no “V” device is used, the thermal expansion tank is not required.
- Install recirculation pump between last fixture and water heater, as shown in Figures 5 and 6.
- Use Honeywell Aquastat “T” where shown.

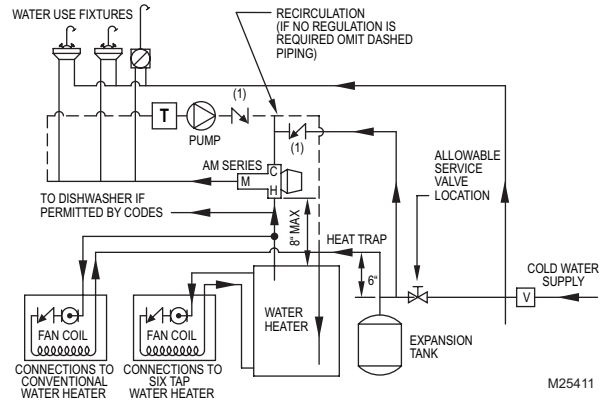

Fig. 6. Water Heater used for Domestic Water and Heating

## OPERATION

The AM-1 1070 Series valve provides for automatic operation through the use of a thermostatic element in the product. The element will control the mixing of the hot and cold supply water to provide mixed, tempered, water to connected fixtures. This provides constant water temperature under different working conditions.

Thermostrip temperature indicator easily indicates water temperature 110° - 140° F (43° - 60° C) for accurate control and quick set-ups.

## Thermostrip Installation Instructions

Clean pipe to mix outlet of valve and firmly apply Thermostrip. Flow water and adjust mixed outlet temperature for desired setting range. Actual mixed water temperature is indicated in green with 2° F and 1° C increments. Blue means slightly lower and brown means slightly higher.

## **! WARNING**

Water temperatures above 120° F (49° C) can cause serious injury. Mixing valve temperature setting should be done by licensed contractor per local code requirement. To ensure correct temperature control use water thermometer at faucet outlet.

Thermal temperature indicator strip is One Time use only for initial system temperature setting. Check date code printed on temperature strip to ensure temperature reading accuracy.



Fig. 7. Thermostrip Temperature Indicator

## VALVE MAINTENANCE

Hard water conditions may result in scale deposits causing binding of internal parts in extreme cases. Cleaning the internal parts will usually restore the valve operating conditions. In some cases it may be necessary to replace the lower assembly.

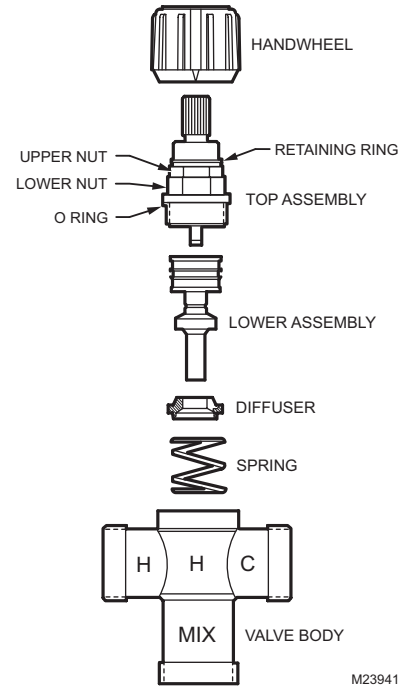

Fig. 8. Exploded View

### To Clean and/or Replace the Lower Assembly Shut Off Water and:

1. With a screwdriver remove screw and hand wheel.
2. Unscrew lower nut (counterclockwise). This removes top assembly.
3. Brass assembly will pop up. Remove lower assembly, diffuser and spring.
4. Carefully remove any scaling (calcium deposits) or foreign particles from valve seat and other internal parts. Use vinegar to remove calcium. Soak parts until calcium becomes soft and can be scrubbed and washed off.

## **! WARNING**

**Do not use solvents or scratch metallic / Teflon coated surfaces.**

5. Replace cleaned spring, diffuser and lower assembly following instructions below or use new replacement kit assembly.
  - A. Insert spring onto diffuser.
  - B. Insert diffuser with spring end first into body.
  - C. Fit valve top assembly into lower assembly and insert into valve. Tighten lower nut. Line up arrow on handwheel Stop with raised arrow on body and hold while tightening upper nut.
  - D. Place handwheel on vane.
  - E. Turn handwheel to desired temperature setting and insert screw.

## TYPICAL SPECIFICATION

Thermostatic Mixing Valve certified to ASSE 1017, ASSE 1070 and CSA approved. Temperature Setting Range (as required, see page one), Maximum Pressure rating of 125 psi (862 kPa), maximum Hot inlet temperature of 212° F (100° C), Nickel plated Brass/Bronze Construction, Teflon coated valve body wear surface, Teflon coated brass shuttle, EPDM O-rings, Proportional design (simultaneous control of hot and cold ports), with either sweat union, NPT (female) union or NPT (female) connections. Valve for domestic hot water applications shall have temperature lock. Design shall be straight thru, with hot and cold ports at the same level. The design shall permit easy access for maintenance, with replaceable thermostatic element.

*CSA® is a registered trademark of Canadian Standards Association.*

*IAPMO® is a registered trademark of the International Association of Plumbing and Mechanical Officials.*

*Teflon® is a registered trademark of E.I. Du Pont De Nemours and Company.*

*Tradeline® is a registered trademark of Honeywell International. Inc.*

## Thermostatic Element Replacement Kit - AM-1-030 RP

The AM-1 Series valves are “in-line” plumbing components (NSF 61 Section 8) in the context of ANSI/NSF 61, Drinking Water System Components - Health Effects. They are not end point devices (NSF 61 Section 9). They are all made of various metals, none of which exceeds 8% lead content, which is the limit imposed by NSF 61 for lead content. They all therefore comply with the Safe Drinking Water Act of 1974, as amended in 1996.

### Automation and Control Solutions

Honeywell International Inc.  
1985 Douglas Drive North  
Golden Valley, MN 55422  
customer.honeywell.com

Honeywell Limited-Honeywell Limitée  
35 Dynamic Drive  
Toronto, Ontario M1V 4Z9

